



## AC230

### Brazed plate heat exchanger with single and double refrigerant circuit

AC230 is the innovative Alfa Laval brazed heat exchanger specifically developed to work in air conditioning, refrigeration, and heat pump applications.

AC230 is a single and double refrigerant circuit unit developed for chillers in the 50-250 kW range and heat pumps in the 30-150 kW; it is suitable to work as an evaporator and as condenser.

The innovation is related to the channel plate design and to the distributor. Compared to existing products, it demonstrates a 5% improvement in COP or 20% in cooling capacity.

Our laboratories verified the heat exchanger, and it achieves the highest market performances with HFC refrigerants such as R407C, R404A, R507 (AC230 model), and R410A (ACH230 model) and with natural refrigerants (CO<sub>2</sub> - propane).

Traditionally, Alfa Laval concentrates extensively on reliability. All the brazed heat exchangers in customers' chiller and heat pump installations are subject to daily fatigue cycles during on/off operations. Our mission is to supply reliable products that prevent damage after a few cycle operations and to assure our customers that the units will not create problems. That's why Alfa Laval worked extensively during the last 50 years to design and develop reliable products and the company invests heavily in R&D.

The AC230 has a patent and a unique integrated distributor pressed together with the plate to assure the highest level of quality and performance reliability. The unit is available with major pressure vessel codes such as PED (Europe), UL (USA), and KHK (Japan).

#### Possible applications

- Evaporator in chiller and heat pumps
- Condenser in chiller and heat pumps



#### Prerequisites

To enable Alfa Laval's representatives to create a quotation, please ensure that they have these specifications:

- Flow rates or heat load required
- Inlet and outlet temperature
- Desired working pressure
- Maximum permitted brine pressure drop
- Connection types
- Brine and refrigerant type

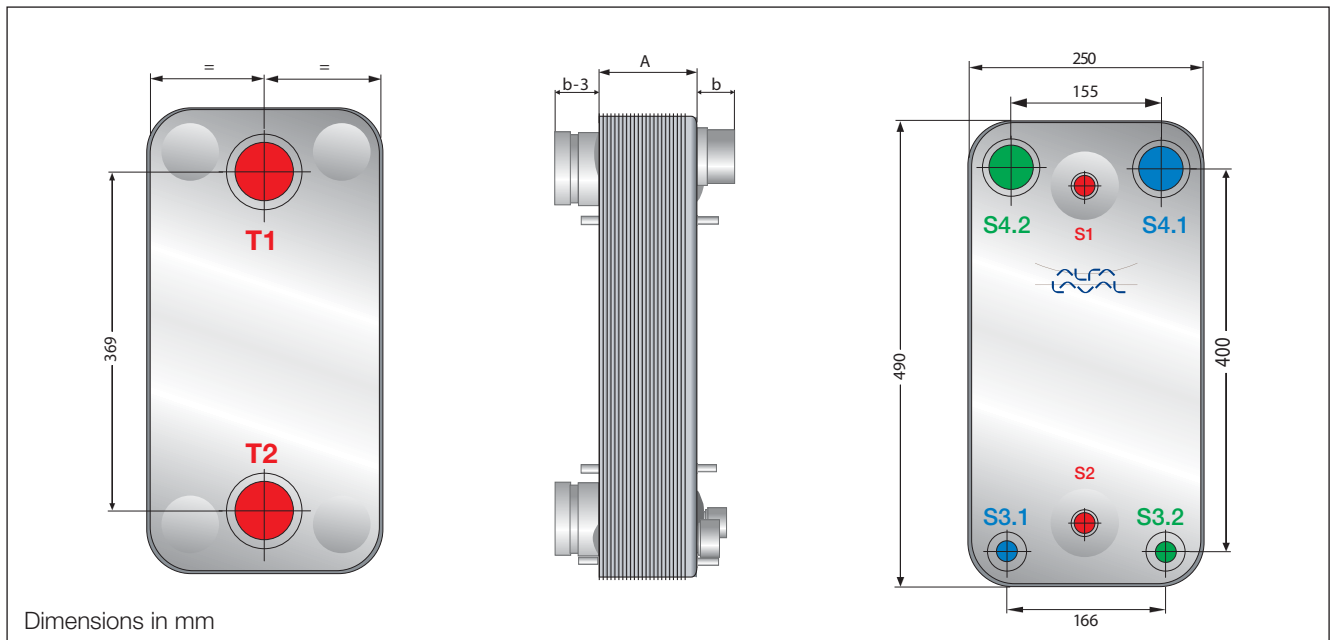

**General data**

Design temperature -160°C / +150°C  
 AC230 design pressure 32 bar  
 ACH230 design pressure 45 bar  
 Maximum flow rate (water side) 55 m³/h

**Standard connections**

Water/brine side 2" 1/2 Victaulic in T1 and T2  
 Threaded, NPT, Gas, Gas con.  
 Refrigerant side 1" 1/8 in S3  
 1" 5/8, 2", 2" 1/4 Rotalock in S4

**Dimensions**

$A = 7.6 + n \times 2.20$  (mm)  
 Weight =  $6.5 + 0.35 n \times$  (kg)  
 n = number of plates

**Alfa Laval brazed plate heat exchangers range**

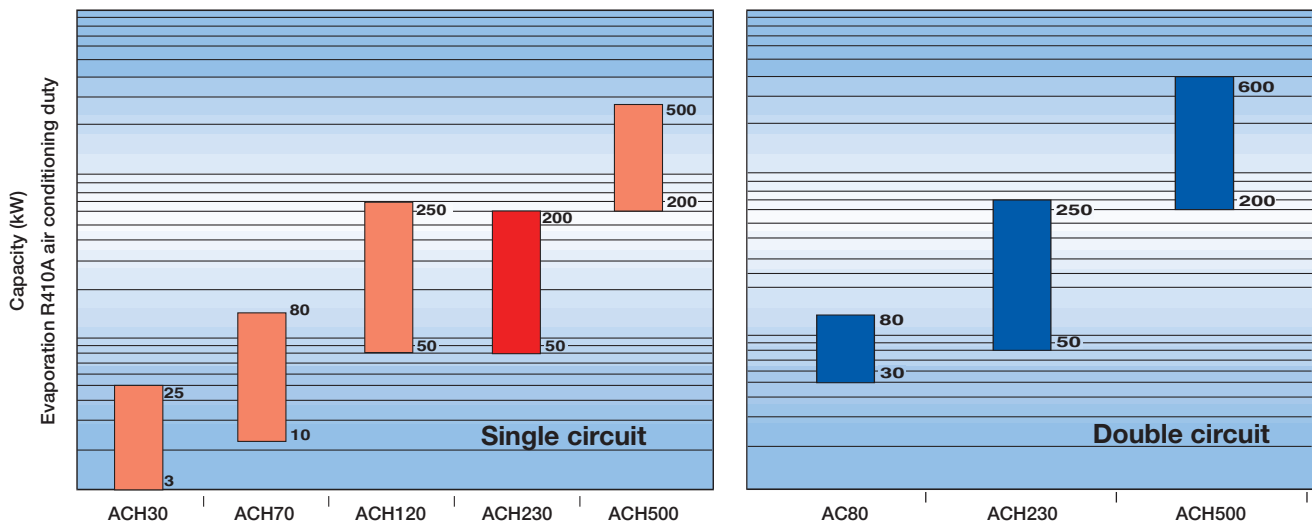

**How to contact Alfa Laval**

Up-to-date Alfa Laval contact details for all countries are always available on our website at [www.alfalaval.com](http://www.alfalaval.com)